

POWER-XTRA

Model : Power-Xtra PX425085 2000mAh Li-Polymer Battery

Ver:1.0

NO: 900.869.503.112

Product Specification (产品技术规格)

No. (序号)	Item (项目)	General Parameter (常规参数)		Remark (备注)
1	Rated Capacity (额定容量)	Typical (标称容量)	2000mAh	Standard discharge (0.2C C ₅ A) after Standard charge (标准充电后 0.2C ₅ A 标准放电)
		Minimum (最小容量)	1960mAh	
2	Nominal Voltage (正常电压)	3.7V		Mean Operation Voltage (即工作电压)
3	Voltage at end of Discharge (放电终止电压)	2.75V		Discharge Cut-off Voltage (放电截止电压)
4	Charging Voltage (充电电压)	4.2±0.03V		
5	Internal Impedance (内阻)	≤60mΩ		Internal resistance measured at AC 1KHz after 50% charge (半电态下用交流法测量内阻) The measure must uses the new batteries that within one week after shipment and cycles less than 5 times (使用出货后不到一个星期及循环次 数少于 5 次的新电池测量)
6	Standard charge (标准充电)	Constant Current 0.2C Constant Voltage 4.2V 0.2C cut-off (持续电流: 0.2C 持续电压: 4.2V 截止电流: 0.02C)		Charge time : Approx 4.0h (充电时间: 大约 4 个小时)
7	Standard discharge (标准放电)	Constant current 0.2C end voltage 2.75V (持续电流: 0.2C 截止电压: 2.75V)		
8	Fast charge (快速充电)	Constant Current 0.5C Constant Voltage 4.2V 0.01 C ₅ A cut-off (持续电流: 0.5C 持续电压: 4.2V 截止电流: 0.1C)		Charge time : Approx 2.5h (充电时间: 大约 2.5 个小时)

POWER-XTRA

Model : Power-Xtra PX425085 2000mAh Li-Polymer Battery

Ver:1.0

NO: 900.869.503.112

Continuous the table 1 (续表 1)

No.	Item	General Parameter	Remark
9	Fast discharge	Constant current 0.5C end voltage 2.75V	
10	Maximum Continuous Charge Current (最大充电持续电流)	1.5A	
11	Maximum Continuous Discharge Current	1.5A	
12	Operation Temperature Range (工作温度范围)	Charge (充电) : 0~45°C	60±25%R.H. Bare Cell (单体电池储存湿度范围)
		Discharge (放电) : -20~60°C	
13	Storage Temperature Range (储存温度范围)	Less than 1 year: -20~25°C (小于一年: -20~25°C)	60±25%R.H. at the shipment state (出货状态时的湿度范围)
		less than 3 months: -20~40°C (小于3个月: -20~40°C)	
14	Pack Dimension (包装后尺寸)	Height: Max 85.5mm (高度: 最大 85.5 mm)	Initial Dimension (初始尺寸)
		Width: Max 50.5 mm (宽度: 最大 50.5 mm)	
		Thickness: Max 4.4mm (厚度: 最大 4.4mm)	

POWER-XTRA

Model : Power-Xtra PX425085 2000mAh Li-Polymer Battery

Ver:1.0

NO: 900.869.503.112

Initial Dimension: (初始尺寸)

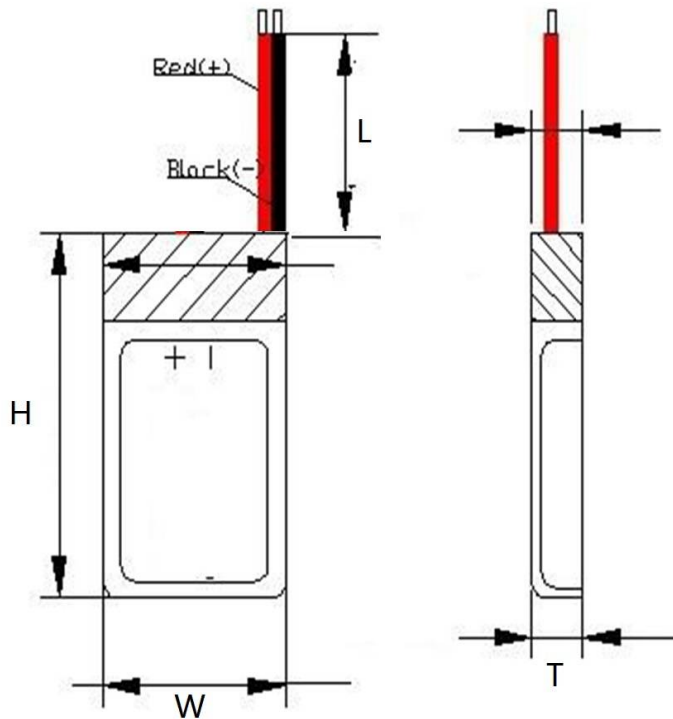

Units (单位)		mm	PCB (保护板)		IC: DW01 / MOS:8205A*1	
Wire(引线)	1007/26#		L(线长)	100±5	tin plating 浸锡	3±1
T (厚度)	4.2 ^{+0.2} _{-0.2}		W (宽度)	50.0 ^{+0.5} _{-0.5}	H (高度)	85.0 ^{+1.5} _{-1.5}
Drawer (绘图)		Checked (审核)		Approved (批准)		Date (日期)
			PX425085 DRAWING			
			Drawing ID (图号)			

POWER-XTRA

Model : Power-Xtra PX425085 2000mAh Li-Polymer Battery

Ver:1.0

NO: 900.869.503.112

Drawing of Label (标签图)

日期按出货月份更改。月份在前，年在后（月/年），标签格式如下，



Packing (包装)

PP袋单独包装，每箱不超 10KG;

中性纸箱，贴箱唛;

箱唛格式如下:

唛头

贴于纸箱正/背两面，唛头尺寸 200*70mm（唛头尺寸视情况而定）:



侧唛

贴于纸箱正/背两侧，侧唛尺寸 130*100mm（侧唛尺寸视情况而定）:

PO NO.	order 16-8	根据每次订单而更改
MODEL NO.	900.869.503.112	
QTY	500PCS	根据每箱数量而定
DATE	2016-07-20	根据出货日期而更改
Made in China		

标签尺寸10*13CM（按情况而定）每箱两面侧面都要贴