



Spec. No.	INR18650-29E	Version No.	1.0
-----------	--------------	-------------	-----

Specification of Product (For xEV & E-bike)

1. Customer :
2. Product : Lithium-ion Rechargeable Cell
3. Model : INR18650-29E
4. Approved by

Division			
Signature			
Date	/ /	/ /	/ /

5. Date of Application (YYYY/MM/DD) : 2018/07/19

6. Supplier : **SAMSUNG SDI Co., Ltd.**
Battery Business Division

Issued	Checked	Approved



Spec. No.	INR18650-29E	Version No.	1.0
-----------	--------------	-------------	-----

Revision history

Revision No.	Date (yr-m-d)	Description	Changes / Author
V1.0	'18-07-19	General version	SH, JUNG WS, SHIN

Spec. No.	INR18650-29E	Version No.	1.0
-----------	--------------	-------------	-----

1. Scope

This product specification has been prepared to specify the rechargeable lithium-ion cell ("Cell" or "Cells") to be supplied to the customer by Samsung SDI Co., Ltd. ("Samsung SDI")

2. Description and Model

2.1 Description	Cell (lithium-ion rechargeable cell)
2.2 Model	INR18650-29E
2.3 Site	Manufactured in China & Korea

3. Nominal Specifications^(*1)

Item	
3.1 Standard Discharge Capacity	Min 2,500mAh (for EV) - Charge : 0.33C(825mA), 4.125V, 0.025C(62.5mA) cutoff @RT - Discharge : 1C(2,500mA), 2.5V cutoff @ RT * 1C = 2,500mA
	Min 2,700mAh (for E-bike) - Charge : 0.5C(1,350mA), 4.2V, 0.02C(54mA) cutoff @RT - Discharge : 0.2C(540mA), 2.5V cutoff @ RT * 1C=2700mA
3.2 Charging Voltage	4.125V (for EV), 4.2V (for E-bike)
3.3 Nominal Voltage	3.70V
3.4 Charging Method	CC-CV (constant voltage with limited current)
3.5 Charging Current rate	0.33C (825mA)
3.6 Discharge Current rate	1C (2,500mA) for EV
3.7 Discharge Cut-off Voltage	2.5V
3.8 Operating Temperature ^(*2) (Cell Surface Temperature)	Charge : 0 to 45°C Discharge : -20 to 60°C
3.9 Cycle life	Capacity ≥ 2,000mAh @ after 1000cycles (for EV) (80% of the standard discharge Capacity @ RT) - Charge : 0.33C(825mA), 4.125V, CCCV 62.5mA cut-off @ RT - Discharge : 1C(2,500mA) , 2.5V cut-off @ RT
3.10 Recovery 80% after storage ^(*3)	1 year : -20~25°C 3 months : -20~45°C 1 month : -20~55°C
3.11 Cell Weight	44.8±2g
3.12 Cell Dimension	Height: 64.87±0.13 mm Diameter: 18.33±0.07 mm

Note ^(*1) : Protection function of the battery pack should be set within the specified charge, discharge and temperature range in Cell Specification.
Item 3.1~3.11 shall follow "7. INR18650-29E Performance Usable Range".

Spec. No.	INR18650-29E	Version No.	1.0
-----------	--------------	-------------	-----

Note (*²) : Discharge OTP(over temp. protection) should not be over 65°C of Cell surface temperature. Protection set should be based on the location of Cell surface with the highest temp increase part of the battery pack.

Note (*³) : If Cell is kept as ex-factory status (30% of charge), the capacity recovery rate shall be more than 80%.

4. Outline Dimensions

See the Fig. 1

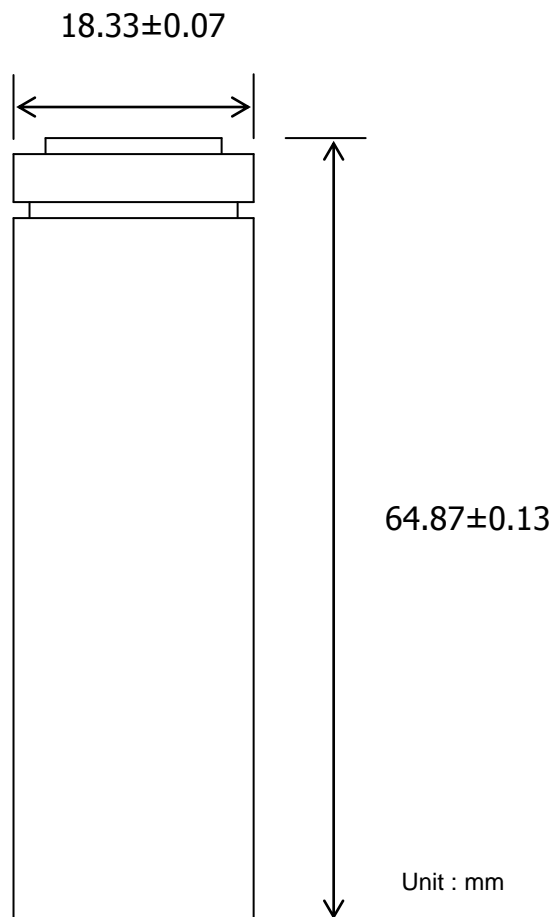

Fig. 1 Outline Dimensions of INR18650-29E

Spec. No.	INR18650-29E	Version No.	1.0
-----------	--------------	-------------	-----

5. Appearance

There shall be no such defects as scratch, rust, discoloration, leakage which may adversely affect commercial value of Cell.

5.1 2D Marking

(1) Purpose

- To reinforce detecting cell defects through comparing OCV & IR before pack manufacturing
 → Check the difference of OCV/IR between OCV/IR of 2D barcode and OCV/IR of customer sorting.
- To improve traceability

(2) 2D Marking Information

- Cell batch number & Serial number (for SDI Internal)
- IR/OCV in outgoing inspection (for Customers)

(3) Size & Location

- Size : 6.5mm * 6.5mm (± 1mm)
- Location : 40 ± 2mm

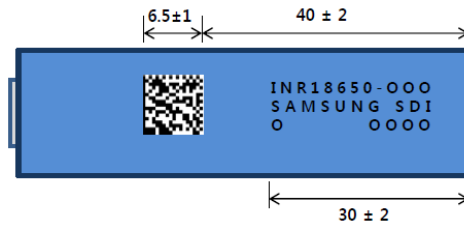

5.2. Appearance (Picture)



Spec. No.	INR18650-29E	Version No.	1.0
-----------	--------------	-------------	-----

6. Standard Test Conditions

6.1 Environmental Conditions

Unless otherwise specified, all tests stated in this specification are conducted at temperature $25\pm 3^{\circ}\text{C}$ and humidity under 60%.

6.2 Measuring Equipment

(1) Amp-meter and Volt-meter

The amp-meter and volt-meter should have an accuracy of the grade 0.5mA and mV or higher.

(2) Slide caliper

The slide caliper should have 0.01 mm scale.

(3) Impedance meter

The impedance meter with AC 1kHz should be used.

7. Characteristics

7.1 Standard Charge (for EV)

This "Standard Charge" means charging Cell with charge current of 0.33C(825mA) and constant voltage 4.125V at 25°C , 0.025C(62.5mA) cut-off.

7.2 Standard Discharge Capacity (for EV)

The standard discharge capacity is the initial discharge capacity of Cell, which is measured with discharge current of 1.0C (2,500mA) with 2.5V cut-off at 25°C within 1 hour after the standard charge.

$$\text{Standard Discharge Capacity} \geq 2,500\text{mAh}$$

7.3 Rated Discharge Capacity (for E-Bike)

The rated discharge capacity is the initial discharge capacity of Cell, which is measured with discharge current of 1C(2,700mA) with 2.50V cut-off at 25°C within 1 hour after the Standard charge.

$$\text{Rated Discharge Capacity} \geq 2,619\text{mAh (97\% of 2,700mAh)}$$

7.4 Initial Internal Impedance (for EV & E-Bike)

Initial internal impedance measured at AC 1kHz after Standard charge.

$$\text{Initial Internal Impedance} \quad 21.0\pm 4.0\text{m}\Omega$$

Spec. No.	INR18650-29E	Version No.	1.0
-----------	--------------	-------------	-----

7.5 Temperature Dependence of Discharge Capacity (For EV)

Discharge capacity comparison at each temperature, measured with discharge constant current 1.0C(2,500mA) and 2.5V cut-off with follow temperature after the standard charging at 25°C.

Charge temperature	Discharge temperature					
25°C	-20°C	-10°C	0°C	25°C	40°C	60°C
Cut-off voltage	2.0V	2.5V	2.5V	2.5V	2.5V	2.5V
Relative capacity	70%	80%	85%	100%	100%	95%

Note: If charge temperature and discharge temperature is not the same, the interval for temperature change is 2 hours.
Percentage as an index of the Standard discharge capacity (=2,500mAh) is 100%.

7.6 Temperature Dependence of Charge Capacity (for EV)

Capacity comparison at each temperature, measured with discharge constant current 1.0C(2,500mA) and 2.5V cut-off at 25°C after the standard charge is as follow temperature.

	Charge temperature				Discharge temperature
	0°C	10°C	25°C	45°C	
Relative Capacity	90%	90%	100%	100%	25°C

Note: If charge temperature and discharge temperature is not the same, the interval for temperature change is 2 hours.
Percentage as an index of the standard discharge capacity (=2,500mAh) is 100%.

7.7 Charge Rate Capabilities (for EV)

Discharge capacity is measured with constant current 1.0C(2,500mA) and 2.5V cut-off after the cell is charged with 4.125V at 25°C as follows.

	Charge Condition		
Current	0.33C (825mA)	0.5C (1,250mA)	1.0C (2,500mA)
Cut-off	0.025C	0.025C	0.025C
Relative Capacity	100%	100%	95%

Note: Percentage as an index of the standard discharge capacity (=2,500mAh) is 100%.

Spec. No.	INR18650-29E	Version No.	1.0
-----------	--------------	-------------	-----

7.8 Discharge Rate Capabilities (for EV)

Discharge capacity is measured with the various currents in under table and 2.5V cut-off after the Standard charge at 25°C.

Current	Discharge Condition			
	0.33C (825mA)	0.5C (1,250mA)	1C (2,500mA)	2C (5,000mA)
Relative Capacity	100%	100%	100%	90%

Note: Percentage as an index of the standard discharge capacity (=2,500mAh) is 100%.

7.8 Cycle Life (for EV)

Each cycle is an interval between the charge [charge current 0.33C(825mA)] with 0.025C cut-off and the discharge [discharge current 1C(2,500mA)] with 2.5V cut-off. Capacity after 1000 cycles.

Capacity \geq 2,000mAh (80% of Standard discharge capacity)

7.9 Cycle Life (for E-bike)

Each cycle is an interval between the charge (charge current 1350mA) with 0.05C(135mA) cut-off and the discharge (discharge current 2,700mA) with 2.50V cut-off. Capacity after 500cycles.

Capacity \geq 2,095mAh (80% of Rated Capacity)

7.10 Storage Characteristics 1 (for EV)

After storage for 7days at 55 \pm 2°C with the standard charge, capacity after storage for 5hr at RT is measured with discharge current 1C(2,500mA) with 2.50V cut-off at 25°C

Capacity recovery(after the storage) \geq 2,250mAh (90% of Standard discharge Capacity)

7.11 Storage Characteristics 2 (for EV)

After storage for 28days at RT with the standard charge, capacity is measured with discharge current 1C(2,500mA) with 2.50V cut-off at 25°C.

Capacity recovery(after the storage) \geq 2,250mAh (90% of Standard discharge capacity)

7.12 Status of Cell as of ex-factory

Cell should be shipped in 3.450V \sim 3.650V Charging voltage range.

Spec. No.	INR18650-29E	Version No.	1.0
-----------	--------------	-------------	-----

8. Safety

: GB/T 31484 31485 31486, UN38.3

9. Warranty

9.1 For EV

Samsung SDI warrants that Cell will be free from defects in manufacturing for a period of [24] months from the date of shipping ("Warranty Period"). In case of defects, Samsung SDI will only replace the affected Cell. However, Samsung SDI shall not be liable for if (i) Cell was improperly installed, repaired, altered or otherwise modified (other than by Samsung SDI), (ii) Cell was subjected to misuse, abuse, negligence or accident, or (iii) Cell was used, handled, stored, sold or distributed in a manner contrary or inconsistent to the handling /use instructions provided in this product specification sheet and the customer environment test guidelines (if any).

9.2 For E-bike

Samsung SDI warrants that Cell will be free from defects in manufacturing for a period of [15] months from the date of shipping ("Warranty Period"). In case of defects, Samsung SDI will only replace the affected Cell. However, Samsung SDI shall not be liable for if (i) Cell was improperly installed, repaired, altered or otherwise modified (other than by Samsung SDI), (ii) Cell was subjected to misuse, abuse, negligence or accident, or (iii) Cell was used, handled, stored, sold or distributed in a manner contrary or inconsistent to the handling /use instructions provided in this product specification sheet and the customer environment test guidelines (if any).

Spec. No.	INR18650-29E	Version No.	1.0
-----------	--------------	-------------	-----

10. Packaging

10.1 Ocean

NO	PART NAME	MATERIAL	Q'ty	NO	PART NAME	MATERIAL	Q'ty
1	PACKING GUIDE	MANILA 300g	2 pcs /BOX	9	ShipLot LABEL	ART PAPER	1 pcs /PALLET
2	CELL	CILINDERICAL	200 pcs /BOX	10	PAL LABEL	ART PAPER	1 pcs /PALLET
3	BOX(PACKING CASE IN)	SW1-E	2 pcs /BOX	11	PALLET	PLASTIC	1 pcs /PALLET
4	BOX(PACKING CASE OUT)	DW1-BA	1 pcs /BOX	12	CORNER BLOCK	C.F.B	8 pcs /PALLET
5	BAG PE	LD-PE	1 pcs /BOX	13	PALLET VINYL	LD-PE	1 pcs /PALLET
6	SILICAGEL	SI	2 pcs /BOX	14	WRAP STRETCH	LD-PE	0.044 ROL/PALLET
7	TAPE	OPP	0.02ROL/BOX	15	BAND (BAND PP)	PP	0.016 ROL/PALLET
8	Product LABEL	ART PAPER	1 pcs/BOX	16	Stack LABEL	ART PAPER	1 pcs /PALLET
				17	Inspection LABEL	ART PAPER	1 pcs /PALLET

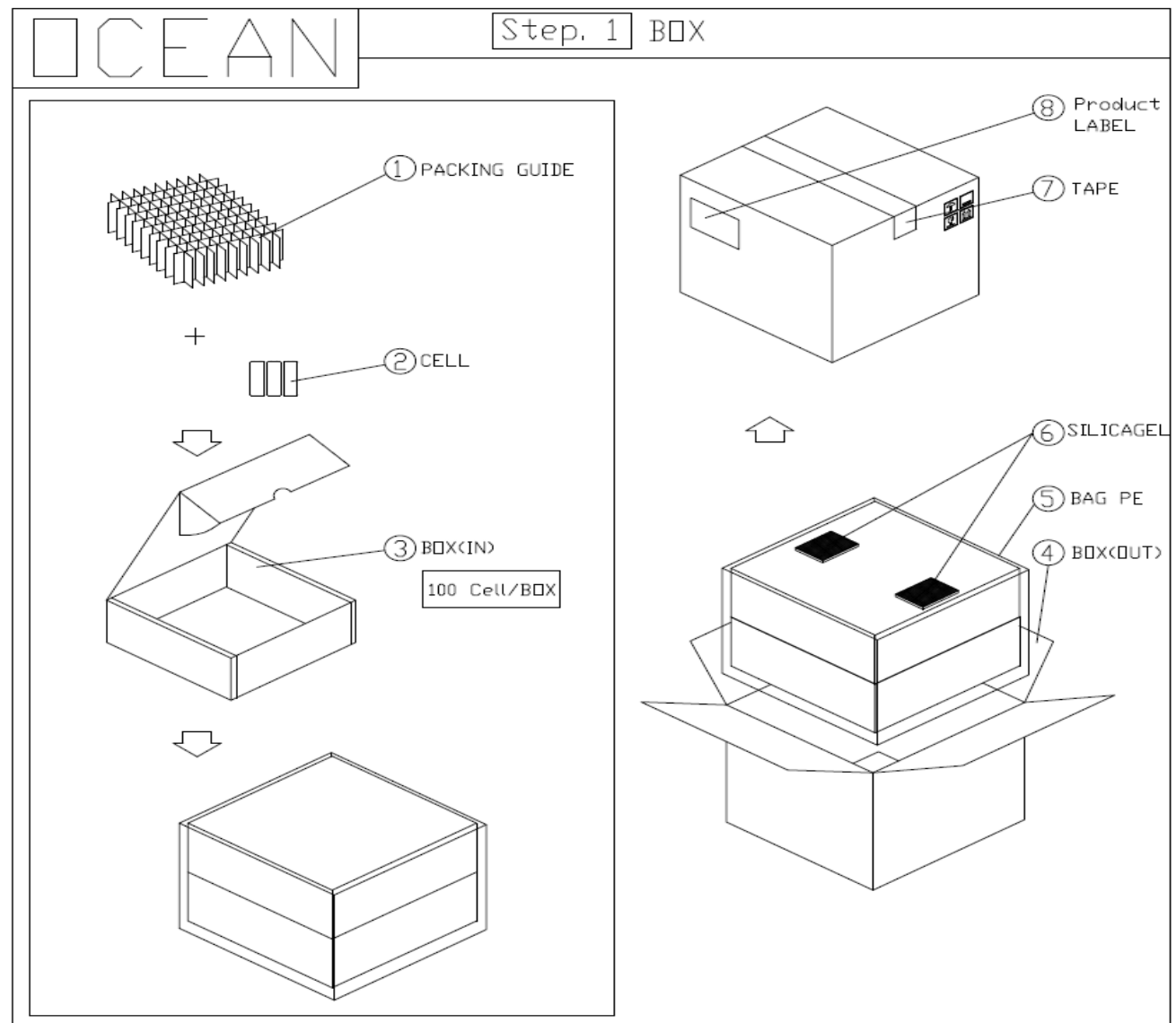

Spec. No.	INR18650-29E	Version No.	1.0
-----------	--------------	-------------	-----

OCEAN

Step. 2 PALLET

->Attach a label on the Box.

⑨ Ship.Lot LABEL

⑩ PAL LABEL

20 X 6 Layer

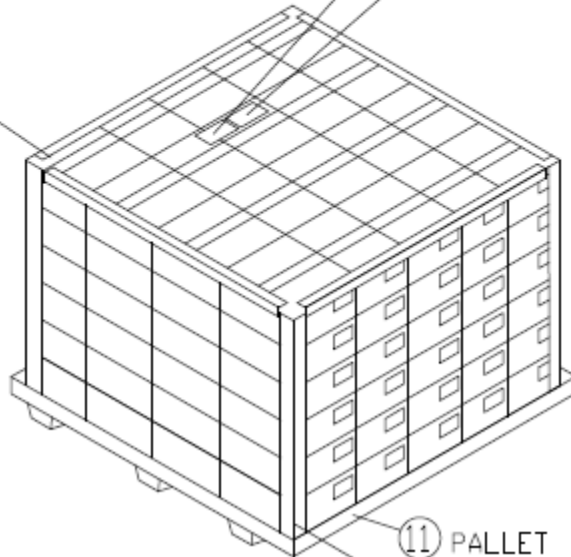

⑪ PALLET

⑫ CORNER BLOCK

200 Cell/Box
 120 Box/Pallet
 24,000 Cell/Pallet
 Full Pallet

->Boxes must piled up in Block Pattern.

Block Pattern

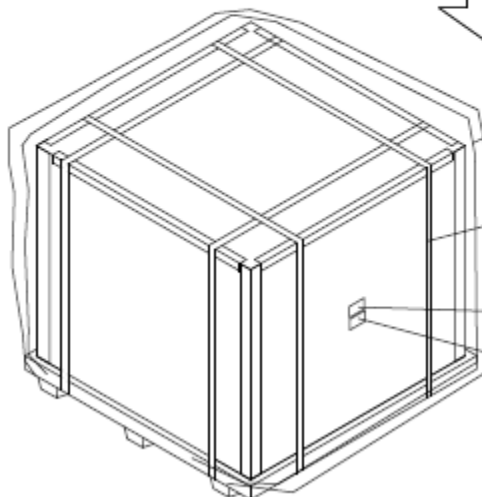
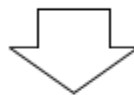

⑬ PALLET VINYL

⑭ WRAP STRETCH

⑮ BAND

⑯ Stack LABEL

⑰ Inspection LABEL

->Attach a label on wrap stretch.

Spec. No.	INR18650-29E	Version No.	1.0
-----------	--------------	-------------	-----

10.2 Air

NO	PART NAME	MATERIAL	Q'ty	NO	PART NAME	MATERIAL	Q'ty
1	PACKING GUIDE	MANILA 300g	2 pcs /BOX	11	CLASS9+Adress LABEL	ART PAPER	1 pcs /BOX
2	CELL	CILINDERICAL	200 pcs /BOX	12	Ship.Lot LABEL	ART PAPER	1 pcs /PALLET
3	BOX(PACKING CASE IN)	SW1-E	2 pcs /BOX	13	PAL LABEL	ART PAPER	1 pcs /PALLET
4	BOX(PACKING CASE OUT)	DW1-BA	1 pcs /BOX	14	PALLET	PLASTIC	1 pcs /PALLET
5	BAG PE	LD-PE	1 pcs /BOX	15	CORNER BLOCK	C.F.B	8 pcs /PALLET
6	SILICAGEL	SI	2 pcs /BOX	16	PALLET VINYL	LD-PE	1 pcs /PALLET
7	Product LABEL	OPP	0.02RDL/BOX	17	WRAP STRETCH	LD-PE	0.044 RDL/PALLET
8	TAPE	ART PAPER	1 pcs /BOX	18	BAND (BAND PP)	PP	0.016 RDL/PALLET
9	CAD LABEL	ART PAPER	1 pcs /BOX	19	Stack LABEL	ART PAPER	1 pcs /PALLET
10	ICAO LABEL	ART PAPER	1 pcs /BOX	20	Inspection LABEL	ART PAPER	1 pcs /PALLET

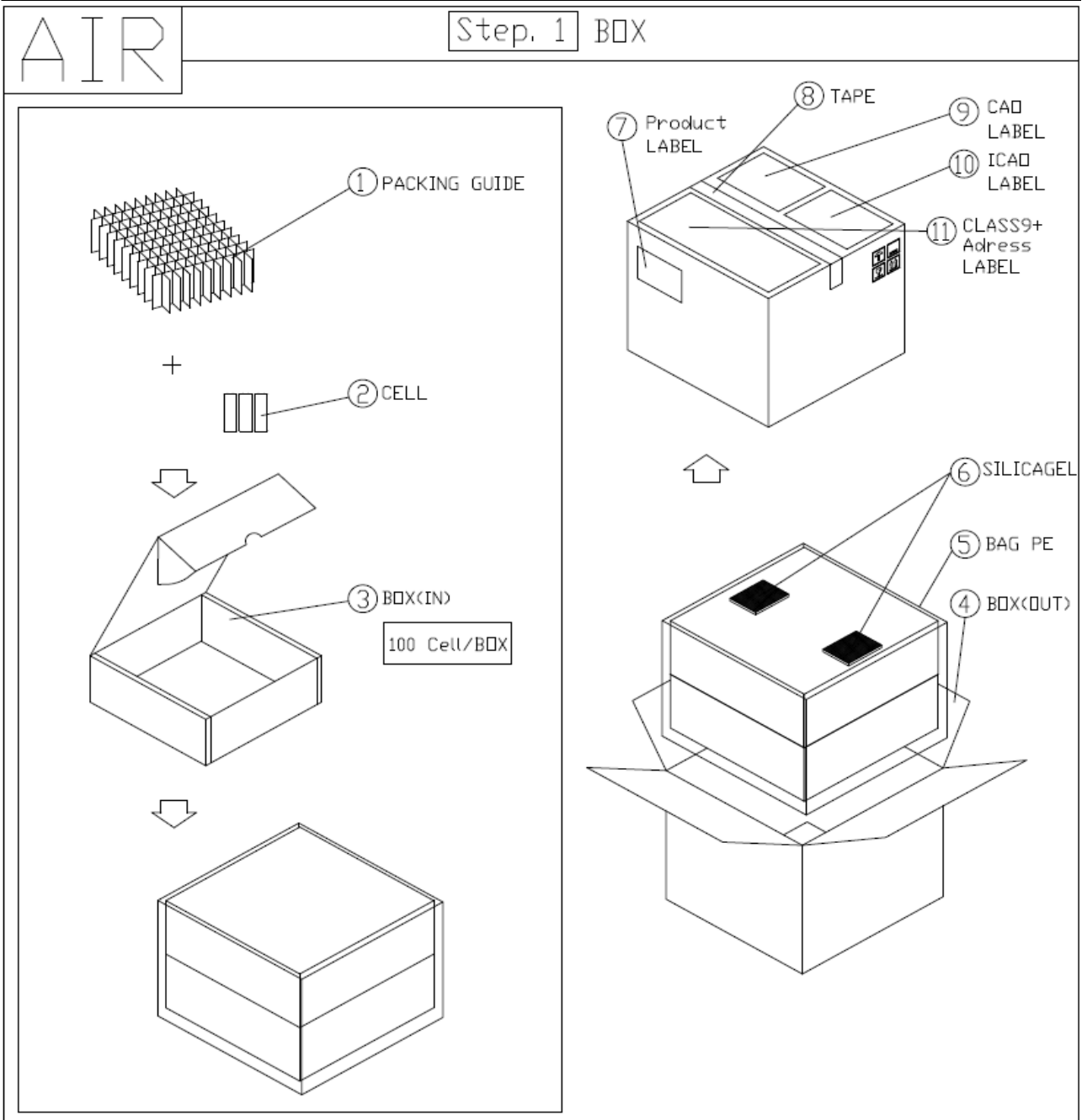

Spec. No.	INR18650-29E	Version No.	1.0
-----------	--------------	-------------	-----

AIR

Step. 2 PALLET

->Attach a label on the Box. ⑫ Ship.Lot LABEL
⑬ PAL LABEL

20 X 6 Layer

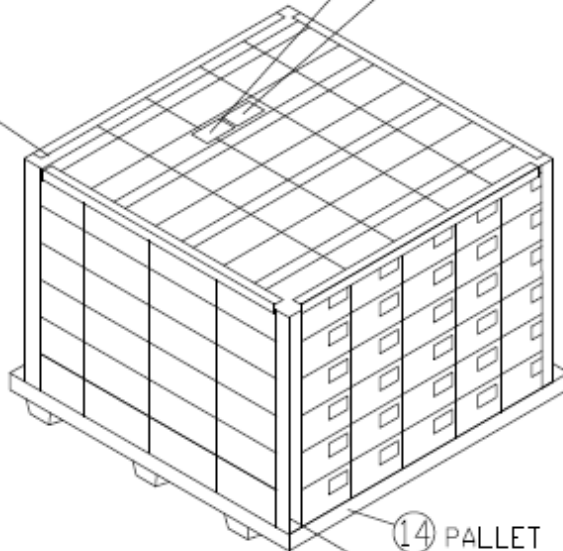

⑭ PALLET
⑮ CORNER BLOCK

200 Cell/Box
120 Box/Pallet
24,000 Cell/Pallet
Full Pallet

->Boxes must piled up in Block Pattern.

Block Pattern

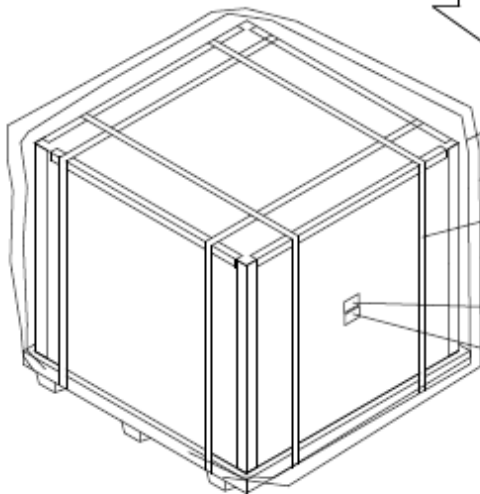
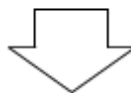

⑯ PALLET VINYL

⑰ WRAP STRETCH

⑱ BAND

⑲ Stack LABEL

⑳ Inspection LABEL

->Attach a label on wrap stretch.

Spec. No.	INR18650-29E	Version No.	1.0
-----------	--------------	-------------	-----

11. INR18650-29E Performance Usable Range

Usable Voltage Range Low Temp Charging Algorithm Check DC/AC Inverter Operating Voltage Check

Cell Surface	Charge Max Voltage (V)			Discharge Min Voltage (V)		
	Operating Limit	Pulse Limit	Safety Limit	Operating Limit	Pulse Limit	Safety Limit
-20°C	Not permitted			2.000V	2.000V	1.500V
-10°C				2.000V	2.000V	1.500V
0°C	4.100V	4.150V	4.200V	2.300V	2.300V	2.000V
10°C	4.100V	4.150V	4.200V	2.300V	2.300V	2.000V
25°C	4.100V	4.150V	4.200V	2.500V	2.300V	2.000V
45°C	4.100V	4.150V	4.200V	2.500V	2.300V	2.000V
50°C	4.050V	4.100V	4.200V	2.500V	2.300V	2.000V
60°C	Not permitted			2.500V	2.300V	2.000V

Usable Current Range

Cell Surface	Charge Max Current (A)				Discharge Max Current (A)				
	2sec	5sec	10sec	Continuous	2sec	5sec	10sec	30sec	Continues
-20°C	Not permitted				2A	1A	1A	1A	1A
-10°C					6A	5A	4A	3A	3A
0°C	1A	1A	0.3A	0.4A	10A	8A	6A	5A	3A
10°C	2A	2A	1A		12A	10A	8A	6A	3A
25°C	3A	2A	2A	0.7A	12A	10A	8A	6A	4A
45°C	5A	3A	2A	0.9A	12A	10A	8A	6A	4A
50°C	5A	3A	2A	1.3A	12A	10A	8A	6A	4A
60°C	2A	1A	1A	0.9A	8A	6A	5A	4A	2A
60°C	Not permitted				6A	4A	3A	2A	1A

Motor Regeneration Charging (SOC 95%)

Usable Discharge Power Limit (30sec)

Cell Surface	Discharge Max Power (W)									
	SOC10	SOC20	SOC30	SOC40	SOC50	SOC60	SOC70	SOC80	SOC90	SOC100
-20~-10°C	2	3	8	14	18	20	28	28	28	28
-10~0°C	1	8	19	25	28	28	28	28	28	28
0~10°C	4	17	22	28	28	28	28	28	28	28
10~20°C	8	22	28	28	28	28	28	28	28	28
20~30°C	28	28	28	28	28	28	28	28	28	28
30~40°C	28	28	28	28	28	28	28	28	28	28
40~50°C	22	22	22	22	22	22	22	22	22	22
50~60°C	14	14	14	14	14	14	14	14	14	14

Usable Charge Power Limit (10sec)

Cell Surface	Charge Max Power (W)									
	SOC0	SOC10	SOC20	SOC30	SOC40	SOC50	SOC60	SOC70	SOC80	SOC90
-20~-10°C	Can not Charging Temperature									
-10~0°C	12	12	12	12	8	7	5	4	2	-
0~10°C	22	22	22	22	20	15	11	7	5	3
10~20°C	22	22	22	22	22	22	22	13	10	4
20~30°C	22	22	22	22	22	22	22	22	15	7
30~40°C	22	22	22	22	22	22	22	22	22	8
40~50°C	18	18	18	18	18	18	18	18	18	8
50~60°C	Can not Charging Temperature									

Usable Discharge Power Limit (continuous)

Cell Surface	Discharge Max Power (W)									
	SOC10	SOC20	SOC30	SOC40	SOC50	SOC60	SOC70	SOC80	SOC90	SOC100
-20~-10°C	2	3	8	14	18	20	28	28	28	28
-10~0°C	1	8	19	25	28	28	28	28	28	28
0~10°C	4	17	22	28	28	28	28	28	28	28
10~20°C	8	22	28	28	28	28	28	28	28	28
20~30°C	19	19	19	19	19	19	19	19	19	19
30~40°C	17	17	17	17	17	17	17	17	17	17
40~50°C	14	14	14	14	14	14	14	14	14	14
50~60°C	9	9	9	9	9	9	9	9	9	9

Usable Charge Power Limit (continuous)

Cell Surface	Charge Max Power (W)									
	SOC0	SOC10	SOC20	SOC30	SOC40	SOC50	SOC60	SOC70	SOC80	SOC90
-20~-10°C	Can not Charging Temperature									
-10~0°C	Can not Charging Temperature									
0~10°C	1.8	1.8	1.8	1.8	1.8	1.5	1.3	1.0	0.8	0.3
10~20°C	3.0	3.0	3.0	3.0	3.0	3.0	3.0	2.1	1.5	0.6
20~30°C	3.0	3.0	3.0	3.0	3.0	3.0	3.0	2.1	1.5	0.6
30~40°C	4.5	4.5	4.5	4.5	4.5	4.5	4.5	3.2	2.2	0.9
40~50°C	3.0	3.0	3.0	3.0	3.0	3.0	3.0	2.1	1.5	0.6
50~60°C	Can not Charging Temperature									

– This above table has been prepared to help minimize field cycle degradation, therefore must be reflected in the customer’s module/pack design.

Spec. No.	INR18650-29E	Version No.	1.0
-----------	--------------	-------------	-----

12. Cell Sorting Guideline

- Cell Stock Condition : Temp 25±3℃, Humidity less than 60%
- FIFO(First in, first out)
- Batch Mixing : Within 1Month (30days) after receiving
- Do not mix use mass production cells with sample cells
- Do not mix use cells from different manufacturing site
- Cell should be checked before being used (appearance, dv and IR etc)

Model	Shipping SOC	Cell OCV	Cell IR
■ INR18650-29E	30%	X bar + 3mV/-4mV	Same as spec.

$$\textcircled{1} \overline{dV} = \frac{\sum_{Cell 1}^{Sample} (OCV1 - OCV2)}{Sample Quantity}$$

· $\overline{OCV1}$ = OCV information of 2D Barcode
(Measured OCV @ Samsung)
· $\overline{OCV2}$ = Present OCV by measuring

- ② Each cell's \overline{dV} screen range : $\overline{dV} - 4mV \leq (OCV1 - OCV2) \leq \overline{dV} + 3mV$
 ※ Standard value (-4/+3mV) will be able to change depending on shipping period.

Spec. No.	INR18650-29E	Version No.	1.0
-----------	--------------	-------------	-----

13. Pack safety Design Guideline

13-1. Pack safety Design Guideline (For electrical design)

Item	Caution	Warning	Control	Protection	Remark
Cell Over Voltage	4.150V	4.175V	4.200V	4.200V	Warning & Protection
Cell Under Voltage	3.40V	3.00V	2.50V	2.50V	Warning & Protection
Warring SOC %	SOC 40%	SOC 30%	SOC 20%	SOC 0%	Power Control
Charging Over Temperature	45°C	50°C	55°C	55°C	Warning & Protection
Charging Under Temperature	10°C	5°C	0°C	0°C	Power Control
Discharging Over Temperature	50°C	55°C	60°C	65°C	Power Control
Discharging Under Temperature	0°C	-10°C	-20°C	-30°C	Power Control
Charging Over Current	0.6C	0.8C	1.0C	1.0C	Protection
Discharging Over Current	4.0C	5.0C	6.0C	6.0C	Protection
Charging Imbalance Voltage	100mV	150mV	200mV	250mV	Warning & Protection
Discharging Imbalance Voltage	200mV	300mV	400mV	500mV	Warning & Protection
Charging Imbalance Temp	5°C	10°C	15°C	15°C	Warning & Protection
Discharging Imbalance Temp	10°C	15°C	20°C	20°C	Warning & Protection
Communication Error			○	○	Protection
Thermal Runaway			○	○	Protection

Spec. No.	INR18650-29E	Version No.	1.0
-----------	--------------	-------------	-----

13-2. Pack safety Design Guideline (For mechanical design)

Sector	Item	Unit	Specification
Module Design	☒ Thermal Runaway Design	Module Design Checking	1. The purpose of gap between each cell in battery pack is; 1) to minimize risk of fire of adjacent battery cells 2) to prevent degradation of cell or CID open due to exposure on high temperature through facilitating heat emission → At least 2.0mm gap between each cell must be maintained. 2. Cell core case shall not be flamed. → Cell core case must be non-flammable level V0 (or above V0).
	☒ Current Distribution Design	Module Design Checking	Basically, battery pack for xEV is composed of significant amount of cylindrical battery cells by serial-parallel. With this significant serial-parallel structure, level of cycle life, heat, voltage imbalance at charging or discharging, and safety level will be effected by current distribution design of the battery pack. → The current distribution design of pack must enable even distribution of current on each cell when charging/discharging.
	☒ Heat Generation (Ni Tab & Cell Body)	1.0C to 2.0C Discharging Test	Abnormal heat source from the welding material can damage the battery (thermal damage). This phenomenon can cause safety or charging/discharging efficiency issues. → The temperature between the welding material and battery cell body must be under 10degC at maximum continuous discharge.
	☒ Non Soldering Design	Welding Design Checking	If battery cell is soldered, this can cause leakage of cell or unpredictable defect due to thermal damage. → Soldering is PROHIBITED. Samsung SDI will NOT be liable for any defects caused by customer's misuse of the battery cells (including soldering).
Pack Design	☒ Thermal Imbalance Check	Simulation / Discharging Test	Thermal management for Li-ion battery pack of xEV that is composed of significant amount of cylindrical Li-ion battery cell is very important. If the customer fails to equalize temperature in the battery pack, this can cause abnormal degradation of cycle life, imbalance, or inefficiency of charging/discharging. → The temperature difference between the center of the battery pack and each side of the pack must be below 5°C when charging, and under 10°C when discharging, which must be facilitated through proper thermal management. ※ If needed, Samsung SDI can request and check thermal distribution record of xEV pack and voltage imbalance data during pack charging/discharging from the customers.
	☒ BOL Charging Imbalance Check	Rated Charging Test	
	☒ BOL Discharging Imbalance Check	1.0C Discharging Test	

- Samsung SDI may, at any time, conduct module or pack analyses at the customer's site to check the customer's compliance with the above specifications. The customer must provide all necessary assistance to Samsung SDI.

- If the parties are unable to resolve issues found during such site inspection, Samsung SDI may refuse to supply further products to the customer.

Spec. No.	INR18650-29E	Version No.	1.0
-----------	--------------	-------------	-----

14. xEV Charging guide (Low Temp, Heating & Regeneration Charging)

Temperature (°C)	< 0	0~5	5~10	10~20	20~30	30~40	40~50	> 50
Charging Condition	Not Permitted	0.15C 4.100V	0.20C 4.100V	0.25C 4.100V	0.33C 4.100V	0.5C 4.100V	0.33C 4.050V	Not Permitted
Heating		Need	X	X	X	X	X	
Cooling						Need	Need	
Quick Charging						Permitted (32±2°C)		

※ Notice

- ✓ Heating Start Temperature : 0°C / Heating End Temperature : 5°C
- ✓ Regeneration Charging < SOC95% , Less than 10sec
- ✓ Quick Charging < 1.0C , 400cycles , Standard Charging < 0.33C , 1000cycles
- ✓ Operating Temperature : 32±2°C , Storage Temperature : 25±2°C (Cooling Guide Line)
- ✓ Discharge Condition : NEDC, NEDC x3 Cycle Life, Using Profile Analysis

- **The above condition must be complied with when low temperature charging, heating, and regeneration charging of the cylindrical Li-ion battery for xEV.**
- **If the customer anticipates any problems in meeting the above conditions, customer must immediately notify Samsung SDI, and the parties will discuss.**

15. Compliance

Customer shall comply with cell's warranty conditions and guidelines in the specification sheet, and customer shall immediately notify Samsung SDI if customer reasonably believes that it cannot comply with the aforementioned conditions and guidelines.

16. Others

16.1 Storage for a long time

If Cell is kept for a long time (3months or more), It is strongly recommended that Cell is preserved at dry and low-temperature.

16.2 Other

Any matters that specifications does not have, should be conferred with between the both parties.

Spec. No.	INR18650-29E	Version No.	1.0
-----------	--------------	-------------	-----

Proper Use and Handling of Lithium Ion Cells

See before using lithium-ion cell

This document has been prepared to describe the appropriate cautions and prohibitions, which the customer should take or employ when the customer uses and handles the lithium ion cell to be manufactured and supplied by Samsung SDI in order to obtain optimum performance and safety.

1. Charging

1.1 Charging current

Charging current should be less than maximum charge current specified in the product specification.

1.2 Charging voltage

Charging should be done by voltage less than that specified in the product specification.

1.3 Charging time

Continuous charging under specified voltage does not cause any loss of performance characteristics. However, the charge timer is recommended to be installed from a safety consideration, which shuts off further charging at time specified in the product specification.

1.4 Charging temperature

Cell should be charged within a range of specified temperatures in the specification.

1.5 Reverse charging

Cell should be connected, confirming that its poles are correctly aligned. Inverse charging should be strictly prohibited. If Cell is connected improperly, it may be damaged.

2. Discharging

2.1 Discharging

Cell shall be discharged continuously at less than maximum discharge current specified in the product specification. In case of the higher discharge current should be set, it shall be discussed together with SDI.

2.2 Discharging temperature

2.2.1 Cell should be discharged within a range of temperatures specified in the product specification.

2.2.2 Otherwise, it may cause loss of characteristics.

Spec. No.	INR18650-29E	Version No.	1.0
-----------	--------------	-------------	-----

2.3 Over-discharging

- 2.3.1 The system should be equipped with a device to prevent further discharging exceeding discharging cut-off voltage specified in the product specification.
- 2.3.2 Over-discharging may cause loss of performance, characteristics of battery function.
- 2.3.3 Over-discharging may occur by self-discharge if the battery is left for a very long time without any use.
- 2.3.4 The charger should be equipped with a device to detect cell voltage and to determine recharging procedures.

3. Storage

3.1 Storage conditions

- 3.1.1 Cell should be stored within a range of temperatures specified as below^{*4}
^{*4} Store the battery at 0 ~ 23°C, low humidity (below 65%), no dust and no corrosive gas atmosphere

3.1.2 Otherwise, it may cause loss of performance characteristics, leakage and/or rust.

3.2 Long-term storage

- 3.2.1 Cell should be used within a short period after charging because long-term storage may cause loss of capacity by self-discharging.
- 3.2.2 If long-term (but not longer than Warranty Period as set forth in Section 9 (Warranty)) storage is necessary, Cell shall be stored at shipping voltage, because storage with higher voltage may cause more loss of performance characteristics.

3.3 Storage period

Samsung SDI shall not be liable for any defects of cell after a period of 12 months from the date of shipping even if Cell is stored in accordance with Sections 3.1 and 3.2 above.

4. Cycle life

4.1 Cycle life performance

- 4.1.1 Cell can be charged/discharged repeatedly up to times specified in the produce specification with a certain level of capacity also specified in the product specification.
- 4.1.2 Cycle life may be determined by conditions of charging, discharging, operating temperature and/or storage.

5. Battery Pack Assembly

5.1 Prohibition of usage of damaged Cell

- 5.1.1 Cell should be inspected visually before battery assembly.
- 5.1.2 Cell should not be used if sleeve-damage, can-distortion and/or electrolyte-smell is detected

Spec. No.	INR18650-29E	Version No.	1.0
-----------	--------------	-------------	-----

5.1.3. When the electrolyte is coming in contact with the skin or eyes, wash immediately with fresh water and seek medical advice.

5.2 Terminals handling

5.2.1 Excessive force on the negative terminal should be avoided when external strip terminal is welded.

5.3 Transportation

5.3.1 If Cell is necessary to be transported to such as the battery manufacturer, careful precautions should be taken to avoid damage of Cell.

6. Others

6.1 Disassembly

6.1.1 Cell should not be dismantled from the battery pack.

6.1.2 Internal short-circuit caused by disassembly may lead to heat generation and/or venting.

6.1.3 When the electrolyte is coming in contact with the skin or eyes, wash immediately with fresh water and seek medical advice.

6.2 Short-circuiting

6.2.1 Short-circuit results in very high current which leads to heat generation.

6.2.2 An appropriate circuitry should be employed to protect accidental short-circuiting.

6.3 Incineration

6.3.1 Incinerating and disposing of Cell in fire are strictly prohibited, because it may cause rupture and explosion.

6.4 Immersion

6.4.1 Soaking Cell in water is strictly prohibited, because it may cause corrosion and leakage of components to be damaged to functions.

6.5 Mixing use

6.5.1 Different types of Cell, or same types but different Cell manufacturer's shall not be used, which may lead to Cell imbalance, Cell rupture or damage to system due to the different characteristics of Cell.

6.5.2 Do not mix use the Cells from different batches/ranks even they are the same Cell types from the same manufacturer.

6.6 Battery disposal

6.6.1 Although the Cell contains no environmentally hazardous component, such as lead or cadmium. the battery should be disposed according to the local regulations when it is disposed.

6.6.2 Cell should be disposed with a discharged state to avoid heat generation by an inadvertent short-circuit.

Spec. No.	INR18650-29E	Version No.	1.0
-----------	--------------	-------------	-----

6.7 Caution

- 6.7.1 The Battery used in this device may present a risk of fire or chemical burn if mistreated.
- 6.7.2 Do not disassemble, expose to heat above 100°C or incinerate it.
- 6.7.3 Replace battery with Samsung SDI battery only.
- 6.7.4 Use of another battery may present a risk of fire or explosion.
- 6.7.5 Dispose of used battery promptly.
- 6.7.6 Keep away from children.
- 6.7.7 Do not disassemble and do not dispose of in fire.

Spec. No.	INR18650-29E	Version No.	1.0
-----------	--------------	-------------	-----

Handling precaution and prohibitions of lithium rechargeable Cells and batteries

Inaccurate handling of lithium ion and lithium ion batteries rechargeable battery may cause leakage, heat, smoke, an explosion, or fire.

This could cause deterioration of performance or failure. Please be sure to follow instructions carefully.

1. Safety precaution and prohibitions

To assure product safety, describe the following precautions in the instruction manual of the application.

2. Danger

2.1 Electrical misuseage

2.1.1 Use dedicated charger.

2.1.2 Use or charge the battery only in the dedicated application.

2.1.3 Don't charge the battery by an electric outlet directly or a cigarette lighter charger.

2.1.4 Don't charge the battery reversely.

2.2 Environmental misuseage

2.2.1 Don't leave the battery near the fire or a heated source.

2.2.2 Don't throw the battery into the fire.

2.2.3 Don't leave, charge or use the battery in a car or similar place where inside of temperature may be over 60°C.

2.2.4 Don't immerse, throw, wet the battery in water / seawater.

2.3 Others

2.3.1 Don't fold the battery cased with laminated film such as pouch and Polymer.

2.3.2 Don't store the battery in a pocket or a bag together with metallic objects such as keys, necklaces, hairpins, coins, or screws.

2.3.3 Don't short circuit (+) and (-) terminals with metallic object intentionally.

2.3.4 Don't pierce the battery with a sharp object such as a needle, screw drivers.

2.3.5 Don't heat partial area of the battery with heated objects such as soldering iron.

2.3.6 Don't hit with heavy objects such as a hammer, weight.

2.3.7 Don't step on the battery and throw or drop the battery on the hard floor to avoid mechanical hock.

2.3.8 Don't disassemble the battery or modify the battery design including electric circuit.

2.3.9 Don't solder on the battery directly.

2.3.10 Don't use seriously scarred or deformed battery.

2.3.11 Don't put the battery into a microwave oven, dryer ,or high-pressure container.

2.3.12 Don't use or assemble the battery with other makers' batteries, different types and/or models of batteries such as dry batteries, nickel-metal hydride batteries, or nickel-cadmium batteries.

2.3.13 Don't use or assemble old and new batteries together.

Spec. No.	INR18650-29E	Version No.	1.0
-----------	--------------	-------------	-----

3. Warning

- 3.1 Stop using the battery if the battery becomes abnormally hot, odor, discoloration, deformation, or abnormal conditions is detected during use, charge, or storage.
- 3.2 Keep away from fire immediately when leakage or foul odors are detected. If liquid leaks onto your skin or clothes, wash well with fresh water immediately.
- 3.3 If liquid leaking from the battery gets into your eyes, don't rub your eyes and wash them with clean water and go to see a doctor immediately.
- 3.4 If the terminals of the battery become dirty, wipe with a dry cloth before using the battery.
- 3.5 Cover terminals with proper insulating tape before disposal.

4. Caution

- 4.1 Electrical misuseage
 - Battery must be charge with constant current-constant voltage (CC/CV).
- 4.2 Others
 - 4.2.1 Keep the battery away from babies and children to avoid any accidents such as swallow.
 - 4.2.2 If younger children use the battery, their guardians should explain the proper handling method and precaution before using.
 - 4.2.3 Before using the battery, be sure to read the user's manual and precaution of its handling.
 - 4.2.4 Before using charger, be sure to read the user's manual of the charger.
 - 4.2.5 Before installing and removing the battery from application, be sure to read user's manual of the application.
 - 4.2.6 Replace the battery when using time of battery becomes much shorter than usual.
 - 4.2.7 Cover terminals with insulating tape before proper disposal.
 - 4.2.8 If the battery is needed to be stored for an long period, battery should be removed from the application and stored in a place where humidity and temperature are low.
 - 4.2.9 While the battery is charged, used and stored, keep it away from object materials with static electric chargers.

5. Safety Handling Procedure for the Transporter

5.1 Quarantine

Packages that are crushed, punctured or torn open to reveal contents should not be transported. Such packages should be isolated until the shipper has been consulted, provided instructions and, if appropriate, arranged to have the product inspected and repacked.

5.2 Spilled Product

In the event that damage to packaging results in the release of Cells or batteries, the spilled products should be promptly collected and segregated and the shipper should be contacted for instructions.

Spec. No.	INR18650-29E	Version No.	1.0
-----------	--------------	-------------	-----

6. Design of positioning the battery pack in application and charger

To prevent the deterioration of the battery performance caused by heat, battery shall be positioned away from the area where heat is generated in the application and the charger.

7. Design of the battery pack

Be sure adopting proper safe device such as PTC specified type or model in Cell Specification.

If you intend to adopt different safety device which is not specified in Cell Specification, please contact Samsung SDI to investigate any potential safety problem.

Be sure designing 2nd protective devices such as PTC & PCM at the same time to protect Cell just in case one protective device is fault.

Please contact following offices when you need any help including safety concerns.

Spec. No.	INR18650-29E	Version No.	1.0
-----------	--------------	-------------	-----

Samsung SDI emergency contact information

- **Samsung SDI Co., Ltd (Headquarter)**
150-20, Gongse-ro, Giheung-gu, Yongin-si, Gyunggi-do, Korea
Tel: +82-31-8006-3100, Fax : +82-31-210-7887

- **Samsung SDI Co., Ltd (Cheonan Factory, Production)**
467, Beonyeong-ro, Seobuk-gu, Cheonan-si, Chungcheongnam-Do, Korea
Tel: +82-41-560-3114, Fax : +82-41-550-3399

- **Samsung SDI China Co., Ltd (Tianjin Factory, Production)**
301726, China Tianjin Developing Zone OF Yi-Xian Park, Wuqing Country, TianJin, China
Tel: +86-22-8212-9971(5300),

- **Samsung SDI Energy Malaysia SDN. Bhd. (Malaysia Factory, Production)**
Lot 635 & 660, Kawasan Perindustrian, Tuanku Jaafar, 71450
Sungai Gadut, Negeri Sembilan Darul Khusus, Malaysia
Tel: (+60)6-677-6160, 6153, Fax: (+60)6-677-6164

- **Samsung SDI America, Inc (San Jose, Sales)**
3655 North First St. San Jose CA 95134
Tel: +1-408-544-4541, Fax: +1-949-260-2221

- **Samsung SDI Europe GmbH (Munich, Sales)**
85737, Oskar-Messter-Strasse 29 Ismaning, Germany
Tel: +49-89-9292-7799(20), Fax: +49-89-9292-7799(99)

- **Samsung SDI Japan Co., Ltd (Tokyo, Sales)**
108-0075, Shinagawa Grand Central Tower 9F, 2-16-4, Konan, Minato-ku, Tokyo, Japan
Tel. +81-3-6369-6401, +81-3-6369-6404 Fax. +81-3-6369-6388

- **Samsung SDI Taiwan Branch (Taipei, Sales)**
7F-1, No.399, Ruiguang Rd., Neihu Dist., Taipei Taiwan (ROC)
Tel +886-2-8178-5900, Fax +886-2-8751-3131

- **Samsung SDI India Branch (New Delhi, Sales)**
1st Fl.M-6 Uppal's Plaza, Jasola District Centre, New Delhi 110025, INDIA
Tel. +91-11-4316-1224, +91-11-4316-1221 Fax. +91-11-4316-1200