



湖南华慧新能源股份有限公司  
HUNAN HUAHUI NEW ENERGY CO.,LTD

VER: 1.0

地址：湖南省益阳市赫山区金秀路桐子壩巷7号  
TEL：0737-2683399 FAX：0737-6185808

DATE:

## Super Li-ion Battery

### Specification

超级锂离子电池

产品规格书

MODEL/型号: **NSC1340**

(3.7V/500mAh)

Prepared By/Date 编制/日期	Checked By/Date 审核/日期	Approved By/Date 批准/日期

Customer Approval	Signature/Date(签名/日期)
	Company Name(公司名称)
	Company Stamp(公司印章)



## 1 Scope (适用范围)

This specification is applied to the reference battery in this Specification and manufactured by HUAHUI NEW ENERGY CO.,LTD

本说明书适用于本书中所提及的、华慧新能源有限公司制造的电池。

## 2 Product Specification (产品技术规格)

### 2.1 Characteristic (参数性能)

Table 1 (表 1)

No. (序号)	Item (项目)	General Parameter (常规参数)		Remark (备注)
		Typical (标称容量)	Minimum (最小容量)	
1	Rated Capacity (额定容量)	500mAh		Standard discharge (0.5C) after Standard charge (标准充电后 0.5C 标准放电)
		450mAh		
2	Nominal Voltage (标称电压)	3.7V		Mean Operation Voltage (即工作电压)
3	Internal Impedance (内阻)	≤60mΩ (单节电芯)		Charged to about 70% of capacity (带电量 70% 的情况下)
4	Standard charge (标准充电)	Constant Current 250mA (0.5C) end Voltage 4.2V 10mA cut-off (恒流: 250mA (0.5C) 截止电压: 4.2V 截止电流: 10mA)		Charge time : Approx 2.5h (充电时间: 大约 2.5 个小时)
5	Standard discharge (标准放电)	Constant current 250mA (0.5C) end voltage 3.0V (恒流: 250mA (0.5C) 截止电压: 3.0V)		
6	Fast charge (快速充电)	Constant Current 500mA (1.0C) end Voltage 4.2V 10mA cut-off (恒流: 500mA (1.0C) 截止电压: 4.2V 截止电流: 10mA)		Charge time : Approx 1.5h (充电时间: 大约 1.5 个小时)
7	Maximum Continuous Discharge Current (最大放电持续电流)	1500mA(3C)		
8	Operation Temperature Range (工作温度范围)	Charge (充电) : 0~40°C		60±25% R.H. Bare Cell (单体电池工作湿度范围)
		Discharge (放电) : -10~60°C		
9	Storage Temperature Range (储存温度范围)	Less than 1 year: -10~20°C (小于一年: -10~20°C)		60±25% R.H. at the shipment state (出货状态时的湿度范围)
		less than 3 months: -10~45°C (小于 3 个月: -10~45°C)		



## 2.2 Cycle Life (循环寿命)

Table 2 (表2)

No. (序号)	Item (项目)	Criteria (标准)	Test Conditions (测试条件)
1	Cycle Life (循环寿命) (0.5C)	Higher than 70% of the Initial Capacities of the Cells (标称容量的70%)	Carry out >500cycle Charge: 0.5C to 4.2V Discharge: 0.5C to 3.0 V Temperature: 25±3°C 循环 >500次 充电: 0.5C to 4.2V 放电: 0.5C 放至 3.0V 温度: 25±3°C

## 3 放电温度特性和保护电路

### 3.1 Temperature Dependence of discharge capacity (放电温度特性)

Table 3 (表3)

Discharge Temperature (放电温度)	-10°C	0°C	25°C	60°C
Discharge Capacity (0.2C) (放电容量(0.2C))	70%	80%	100%	95%

### 3.2 Protection circuit(保护电路)

The battery is not equipped with a PCM, customers in the use of should be effective protective measures to prevent the batteries used in the process of filling appeared, discharge, the flow, short circuit of the case.

本电池没有配备保护板，客户在使用时应有效的保护措施，以防止电池出现过充，过放，过流，短路的情形。

## 4. Note For Use Of Battery(电池组使用说明)

(N/A)



## 5. Cell Mechanical characteristics and Safety Test (电芯安全测试及机械特性)

Table 5 (表 5)

(Safety Test)

Item (项目)	Battery Condition (电池要求)	Test Method (测试方法)	Requirements (要求)
Vibration Test 振动测试		After standard charging, fixed the cell to vibration table and subjected to vibration cycling that the frequency is to be varied at the rate of 1Hz per minute between 10Hz an 55Hz, the excursion of the vibration is 1.6mm. The cell shall be vibrated for 30 minutes per axis of XYZ axes. 将标准充电后的电芯固定在振动台上，沿 X、Y、Z 三个方向各振动 30 分钟，振幅 1.6mm，振动频率为 10Hz~55Hz，每分钟变化 1Hz。	No leakage 无泄漏 No fire 不起火
Crush (挤压试验)	Fresh, Fully charged (充满电的新电池)	Crush between two flat plates. Applied force is about 13kN(1.72Mpa) for 30min. (电池放置在两块平面金属板间，施加 13KN (1.72Mpa) 的作用力，且持续保持 30 分钟)	No explosion, No fire (无起火无爆炸)
Short Circuit (短路试验 20℃)	Fresh, Fully charged (充满电的新电池)	Each test sample battery, in turn, is to be short circuited by connecting the (+) and (-) terminals of the battery with a Cu wire having a maximum resistance load of 0.05 Ω .Tests are to be conducted at room temperature(20±2℃ ). (在常温下约 20±2℃ 依次把每个样品电池的正负极用铜线连接起来使电池外部短路--线路总电阻不超过 0.05Ω )	No explosion No fire The temperature of the surface of the Cells are lower than 150℃ (无起火无爆炸 电池表面温度应低于 150℃)
Impact (冲击试验)	Fresh, Fully charged (充满电的新电池)	A 56mm diameter bar is inlayed into the bottom of a 10kg weight. And the weight is to be dropped from a height of 1m onto a sample battery and then the bar will be across the center of the sample. (用一条直径为 56mm 的圆棒放置在电池中央，将一 10Kg 的重锤从 1m 的高度垂直落下在电池的中心位置)	No explosion, No fire (无起火无爆炸)
Forced Discharge (过放试验)	Fresh, Fully charged (充满电的新电池)	Discharge at a current of 1 C for 2.5h. (以 1C 的电流放电 2.5 小时)	No explosion, No fire (无起火无爆炸)

## 6. Handling of Cells (电池操作注意事项)

### 6.1 Cell fixing (电池的固定)

The cell should be fixed to the battery pack by its large surface area.

No cell movement in the battery pack should be allowed. **(Forbidden to shake the +/- pins of battery)!**

电池最大面积的一面应该固定在外壳上，安装后电池不能有松动**(严禁摇晃电“+/-”极性导针)!**

### 6.2 Inside design (电池外壳内部设计)

No sharp edge components should be insides the pack containing the LIP cell.

外壳内安装电池的部位不应有锋锐边。



湖南华慧新能源股份有限公司  
HUNAN HUAHUI NEW ENERGY CO.,LTD

VER: 1.0

地址：湖南省益阳市赫山区金秀路桐子壩巷7号  
TEL：0737-2683399 FAX：0737-6185808

DATE:

### 6.3 Battery soldering(电芯加工焊接)

Electric soldering iron bit temp.: 320~350℃

Soldering time < 3S

电池应用时极性导针焊接铬铁嘴温度设定:320~350℃ 焊接时间<3秒!

### 6.4 Special Instruction(特别说明):

**The “+” or “-” pin of Huahui Super Li-ion Battery shall never be touched with battery shell to form circuit; otherwise the battery will be damaged.**

**华慧新能源所提供的超级锂圆柱形锂离子电池在应用时绝对不允许电池的“+”极性或者“-”极性与电池壳体形成回路,否则将永久性损坏电池!**

## 7. Others (其它)

### 7.1 Prohibition of disassembly (禁止拆卸)

1) Never disassemble the cells 不要拆卸电池

The disassembling may generate internal short circuit in the cell, which may cause gassing, firing, explosion, or other problems. 拆卸电池会发生电池内部短路,会引起起火/爆炸/有害气体或者其它问题

2) Electrolyte is harmful 电解液是有害的

LIP battery should not have liquid from electrolyte flowing, but in case the electrolyte come into contact with the skin, or eyes, physicians shall flush the electrolyte immediately with fresh water and medical advice is to be sought.

万一电解液沾到皮肤/进入眼睛,应立即用清水冲洗以及求助医生

### 7.2 Prohibition of dumping of cells into fire (不要把电池倾倒入火中)

Never incinerate nor dispose the cells in fire. These may cause explosion of the cells, which is very dangerous and is prohibited.

不要焚毁电池, 否则会致电池爆炸, 这个很危险, 必须禁止。

### 7.3 Battery cells replacement (更换电池)

The battery replacement shall be done only by either cells supplier or device supplier and never be done by the user.

更换电池应由电池生产商或设备供应商完成, 用户不要自行更换。

### 7.4 Please do not exceed the specification range using the battery.

请不要超出本规格书范围使用电池。

## 8. Period of Warranty (保质期)

The period of warranty is 1 year from the date of shipment. Hunan Huahui new energy guarantees to give a replacement in case of cells with defects proven due to manufacturing process instead of the customer abuse and misuse.

电池的保质期从出货之日算起为 1 年。如果证明电池的缺陷是在制造过程中形成的而不是由于用户滥用及错误使用造成, 本公司负责退换电池。

## 9. Storing the Batteries (电池的存放)

**The batteries should be stored at room temperature, charged to about 30% to 50% of capacity.**

**We recommend that batteries be charged about once per half a year to prevent over discharge.**

电池应当在室温下存放, 应充到 30%至 50%的电量。如长时间储存, 建议每半年充一次电以防止电池过放电。



湖南华慧新能源股份有限公司  
HUNAN HUAHUI NEW ENERGY CO.,LTD

VER: 1.0

地址：湖南省益阳市赫山区金秀路桐子壩巷7号  
TEL：0737-2683399 FAX：0737-6185808

DATE:

10. Initial Dimension: (初始尺寸)

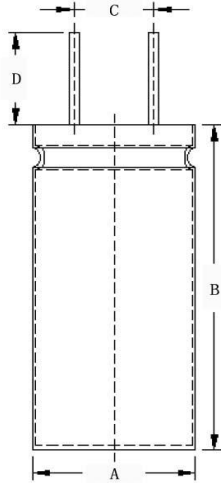

单位: mm 公差:  $\pm 0.2$

项目	参数
A(直径)	13.2
B(长度)	40.2
C(引脚间距)	5.3
D(引脚规格)	直径 $\varnothing 0.8$ *长度 $10 \pm 1$

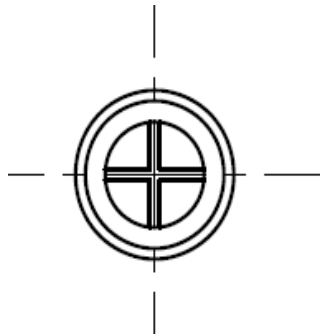

Units (单位)	mm		Weight(重量)	12 $\pm 1$ g	
Connector/插头	无				
Wire(引线)	无		L(线长)	无	
D (直径)	W (宽度)		/	H (高度)	
Drawer (绘图)	Checked (审核)	Approved (批准)	Date (日期)		
<b>HUAHUI NEW ENERGY</b>			<b>NSC1340 DRAWING</b>		
			Drawing ID (图号)		