

SPECIFICATIONS OF SINGLE CELL

Type	Nickel-Cadmium / Ni-Cd
Model	D / 4500 mAh

TECHNICAL INFORMATIONS

Item	Specifications	Conditions
Nominal Voltage	1.2V	
Nominal Capacity	4.500 mAh	Standard Charge/Discharge
Typical Capacity	4.730 mAh	
Standard Charge	450 mA(0.1C) × 16 hrs	Ambient temperature of 20±5°C, Relative Humidity: 65±20%
Standard Discharge	900mA (0.2C)	to 1.0V/cell / -20°C to 60°C
Rapid Charge	1.000mA for 2.6 hours	-delta V controlled: 15mV/cell cut-off dT/dt controlled: 1°C per min
Trickle Charge	0.03mA to 0.05C	Ta=0 ~ 45°C
Fast Discharge	0.3C for 4.3 hours -delta V controlled: 15mV/cell cut-off. dT/dt controlled: 1°C per min.	10°C to 40°C
Maximum Continuous Discharge Current	4.500mA	1C
Storage Temperature	-20 °C ~ 35°C	Discharged state
Weight	118gr. / approx.	
Open Circuit Voltage(OCV)	≥1.25V	Within 1hr after standard charge
Internal Impedance	≤16mΩ	The initial internal resistance is measured at 1KHz within one hour after standard charge.
Overcharge	No leakage nor explosion	The overcharge test is measured with a discharge current of 0.2C and a discharge final voltage of 1.0V/cell within 1-4 hours after charging for 28 days at a current of 0.1C. Check cell appearance after overcharge.
Charge Retention	≥900mAh	After standard charge and storage time of 28 days at an ambient temperature of 20°C±2°C, the capacity is measured with a discharging current of 0.2C and a discharge final voltage of 1.0V.
Cycles Test	≥500 Cycle	IEC61951-2:2003

TECHNICAL DRAWINGS

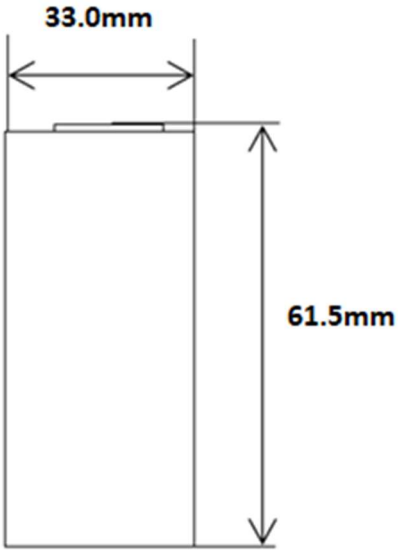
Item	Specifications	Drawings
Diameter	33.0 +0 / -1.0 mm	
Height	61.5 +0 / -1.5 mm	
IMAGE		
