

Data Sheet

Item	Contents		Criteria (Adjustable)
1	Model	HCX-D190	10S-10A working current
2	Voltage	Charging voltage	42V
3	Current	Maximal continuous charging current	10A
		Maximal continuous discharging current	10A
		Current consumption	≤20μA
4	Overcharge Protection	Over charge detection voltage	4.28±0.025V
		Over charge detection delay time	0.5~2S
		Over charge release voltage	4.08V±0.05V
5	Over Discharge Protection	Over discharge detection voltage	3.00V±0.05V
		Over discharge detection delay time	50~200mS
		Over discharge release voltage	3.00V±0.1V
6	Over Current Protection	Over current detection voltage	0.1V~0.2V
		Over current detection current	25±10A
		Detection delay time	5~20mS
		Release condition	Cut load,automatically recover
7	Short Circuit Protection	Detection condition	Exterior shot circuit
		Detection delay time	200~500uS
		Release condition	Cut load,automatically recover
8	Balance	Balance voltage for single cell	4.2V±0.025V
		Balance current for single cell	84±10mA
9	Resistance	Inner resistance	≤20mΩ
10	Temperature	Operating temperature range	-40 ~ +85°C
		Storage temperature range	-20~ +125°C
11	Size (L*W*T)	L60mm*W50mm*T15mm	

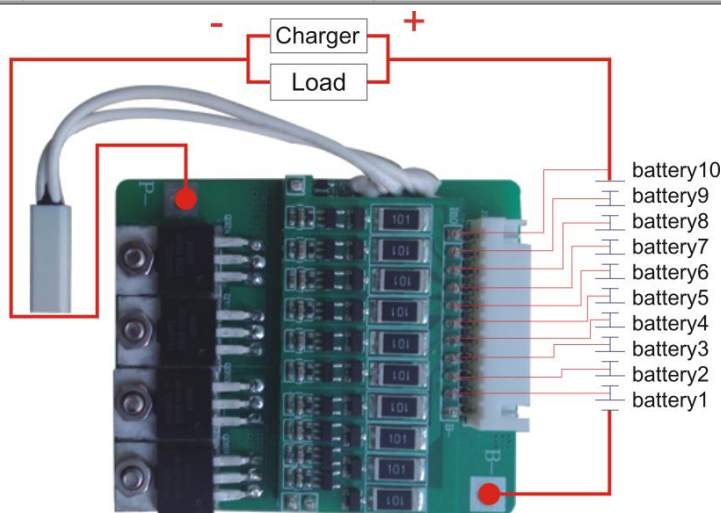

Remarks:

Charge, Discharge at same Port
 P+ = B+ / Charge+ / Discharge+
 P- = Charge- / Discharge-

*Note: Characteristics subject to change without notice.